



## LOADING EQUIPMENT

C350, QUICK-LIFT, SPEED-LIFT



[WWW.KURIS.DE](http://WWW.KURIS.DE)

## C350

### FOR CRADLE-SPREADING MACHINE

By motor and chain driven lifting device with two platforms for lifting, storing and loading of fabric balls up to a diameter of max. 40 cm. Particularly suitable for loading and unloading of a cradle-spreading machine which operates without rods.

The motor of the loading device is controlled and moved by a frequency converter and a worm gear. Its holding position is fixed by a magnetic brake.

#### TECHNICAL SPECIFICATIONS:

Lifting force:	max. 350 kg
Machine length:	approx. 1150 mm
Machine height:	approx. 2480 mm
Total width:	approx. 2440 mm
Max. opening:	2020 mm
Max. ball diameter:	400 mm
Max. lifting height:	max. 1200 mm
Min. lifting height:	min. 160 mm
Lifting gear:	chain single: Type 08B1-DIN 8187, Breaking load 18200 N

#### Rated power supply:

Engine power:	1.5 kW
Operating voltage:	32 V, 50/60 Hz

Machine model according to EC directive

Running noise:	65 dB (A) measured at a distance of 1 m at running idle
----------------	---



2 bottoms as fabric storage

The C350 is equipped with two loading platforms, which can be moved steplessly upwards and downwards by using the manual control. The fabric rolls can be rolled directly from the forklift or a transport trolley onto the platform.

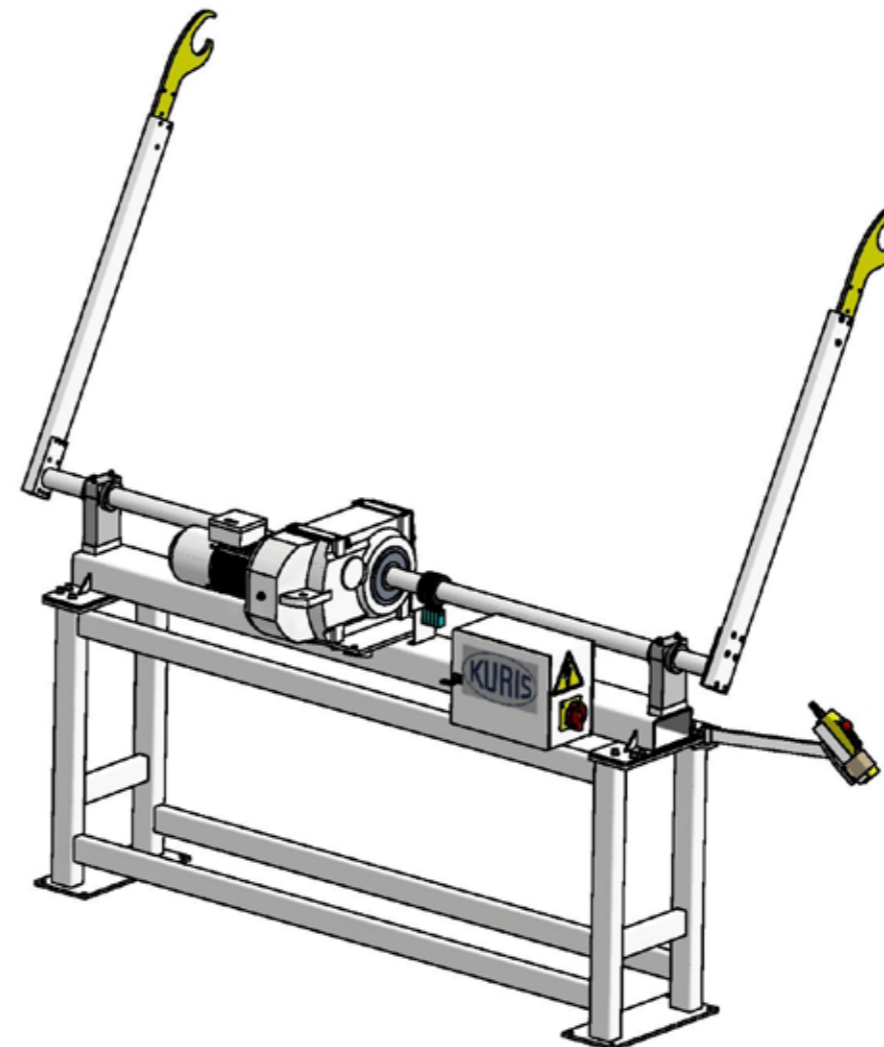

The Quick-Lift unburdens the operator considerably. The Quick-Lift makes it easier for the spreading machine to be equipped with a fabric rod and even more economical.

It is available in various mounting versions:

- mounting on the table
- installation behind the table
- as a mobile version
- in combination with a shuttle

## Quick-Lift

### MEANT FOR SPREADING MACHINES WITH RODS

The Quick-Lift by Kuris loads and unloads the spreading machine with roll material. Two swivel arms lift the roll material, for example from the floor into the machine.

In combination with the thread-in process of a KURIS spreading machine, the loading and unloading is particularly simple and very efficient. After spreading, the unloading of the fabric roll will be executed by the grippers or hooks without any hand grips on the Quick-Lift.

The Quick-Lift is mounted on the table or a special rack and can lift the fabric rolls from the floor into the spreading machine. Two speeds allow for a quick pick-up as well as a gentle loading of the fabric roll. The Quick-Lift can also be installed on a shuttle, so that two side-by-side spreading machines can be operated by only one loading device. Subsequent mounting on an already existing line of the spreading machine is possible.

#### TECHNICAL SPECIFICATIONS:

Roll weight:	max. 120 kg
Material roll diameter:	max. 1000 mm
Overall height:	2280 mm
Working width:	1680 mm to 2280 mm

#### Rated power supply:

Power:	2,2 kW
Operating voltage:	230/400 V, 50 Hz

Machine model according to EC directive

Running noise:	65 dB (A) measured at a distance of 1 m at running idle
----------------	---



## Loading unit

INCLINED UNIT MEANT FOR A MACHINE WITH CRADLE

## Speed-Lift

INTEGRATED INTO A SPREADING MACHINE WITH RODS

The rolled goods can be picked up directly from the table level by the Speed-Lift and inserted into the rod winding-up of the Shuttle / A23. The speed-lift is controlled by the control unit of the spreading machine.

### TECHNICAL SPECIFICATIONS:

Roll weight:	max. 60 kg
Material roll diameter:	max. 600 mm
Working width:	1680 mm to 2280 mm

### Rated power supply:

Power:	1 kW
Operating voltage:	230 V, 50/60 Hz

Machine model according to EC directive

Running noise:	65 dB (A) measured at a distance of 1 m at running idle
----------------	---



Loading unit-inclined lift for a machine with cradle

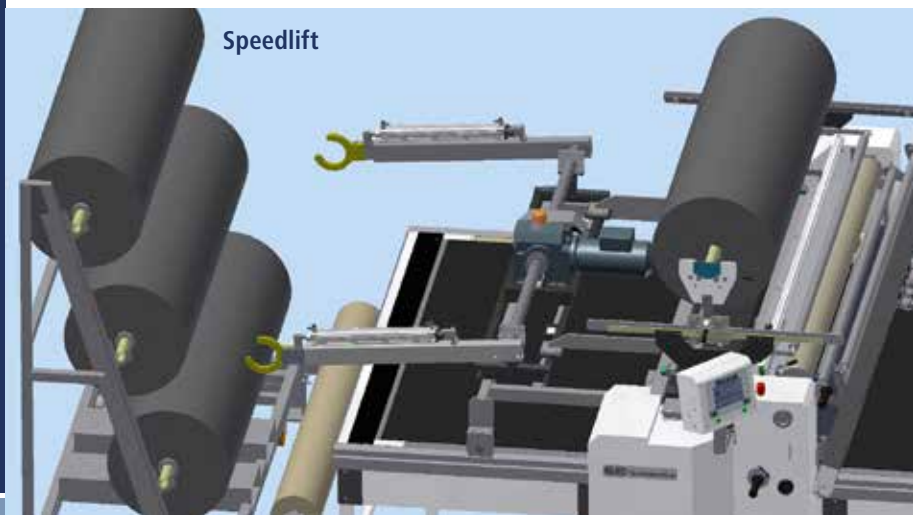

Speedlift

### ADVANTAGES:

- + saves off-peak
- + relieves your employees
- + ergonomic application

The comprehensive product range allows solutions made for your requirements. Spreading and cutting systems are available in our showroom for general demonstration as well as for test cuts with your own materials. **You are kindly asked to make an appointment with us. We look forward to assist you any time!**

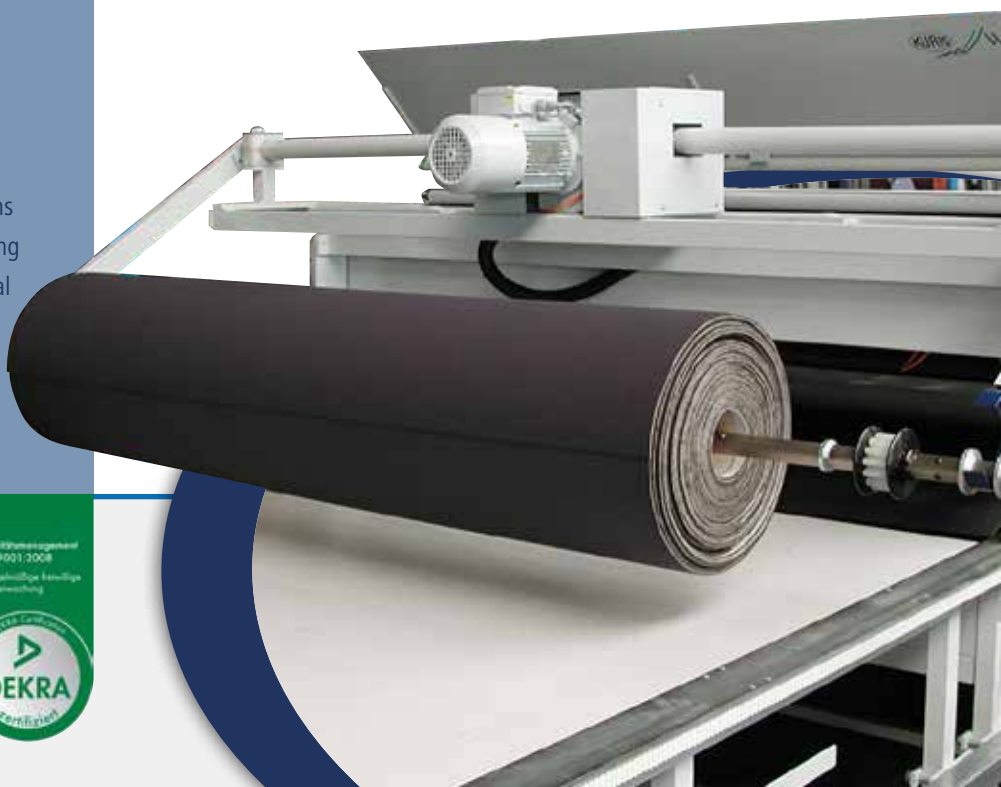

### Kuris Spezialmaschinen GmbH

Degginger Straße 6  
D-73326 Deggingen - Reichenbach

Fon: +49 (0) 73 34 - 9 24 80 - 0  
 Fax: +49 (0) 73 34 - 9 24 80 - 69  
 E-Mail: [info@kuris.de](mailto:info@kuris.de)  
 Web: [www.kuris.de](http://www.kuris.de)

